

Universal Harness Kit – HRN-GS16K2

For the most up-to-date version, please visit: gtb.page.link/52hN



! IMPORTANT: Intended for most light-duty and medium-duty vehicles – not intended for generic heavy-duty vehicle applications. For heavy-duty trucks, always use a vehicle-specific harness when offered by Geotab or the vehicle manufacturer (see [Harness Identification and Application \[PUB\]](#) and [Harness Assessment Cheat Sheet GUIDE V2.0 \[PUB\]](#)). Where a heavy-duty truck-specific harness is not offered by Geotab or the vehicle manufacturer, use the adapter harness (HRN-CG13S1) for any 16-pin (OBDII) installation method to avoid possible GO device damage.

The HRN-GS16K2, an OBDII T-harness kit with twelve mounting brackets, connects a Geotab® GO device to most light-duty and medium-duty vehicles internationally. The HRN-GS16K2 contains the mounting adapters listed below and the adapter plastic is numbered for easy reference (see Adapters below for details).

- North American Flange Mount
- North American Extended Flange Mount
- North American Snap-In Mount
- North American Slide & Lock Mount
- European Lock Mount
- Asian Snap-In
- European Latch & Snap
- VW Snap-In
- BMW Slide & Lock
- Ford Round Snap-In
- Iveco Slide & Lock
- Volvo Slide Mount

Harness Technical Specifications

Weight	135 g
Size	Max Length: 670 mm Max Width: 40.7 mm
Material	Universal Core Connector: PBT Wire Jacket: Mesh Sheathing
Connectors	2 × Universal Core Connector 1 × 24 V compatible ALDL Connector
Power Output	8 V to 36 V
Current Rating	5 A
Temperature Rating	-40 to +85 °C
Adapters	See Below

WARNING! The HRN-GS16K2 harness kit is designed and intended for use only with the GO device or Geotab-authorized accessory devices. Professional installation from a Geotab Authorized Installer is required. Read and follow the complete GO device installation instructions (goo.gl/rkLRiA) as well as these installation instructions to prevent serious personal injury or significant damage to your vehicle.

Adapters

1

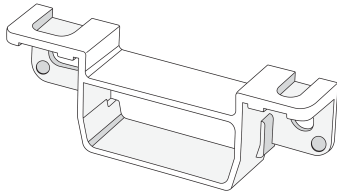

North American Flange Mount

- Ford
- GM
- Chrysler

7

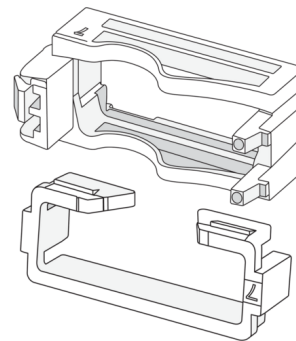

European Latch & Snap

- Fiat
- Citroën
- Peugeot

2

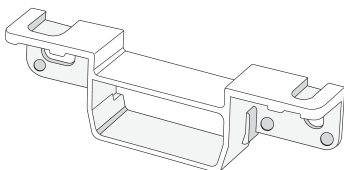

North American Extended Flange Mount

- Ford

8

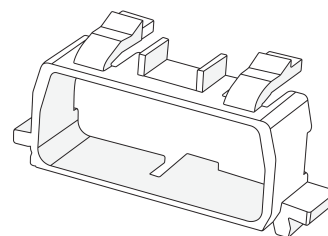

VW Snap-In

- Volkswagen
- Audi

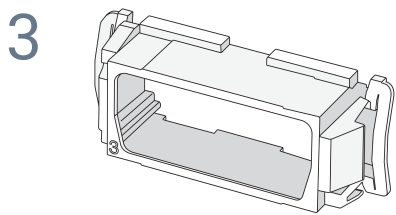

North American Snap-In Mount

- Chrysler

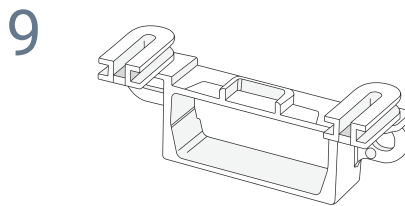

BMW Slide & Lock

- BMW

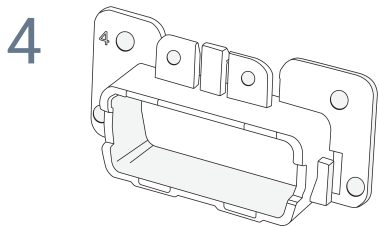

North American Slide & Lock Mount

- Ford
- GM

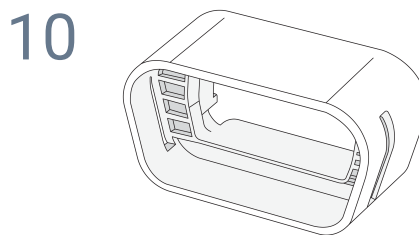

Ford Round Snap-In

- Ford

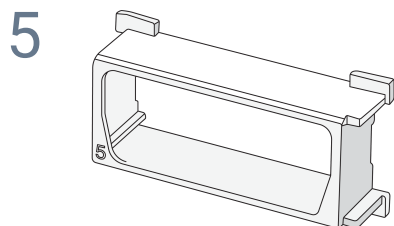

European Lock Mount

- Mercedes
- BMW

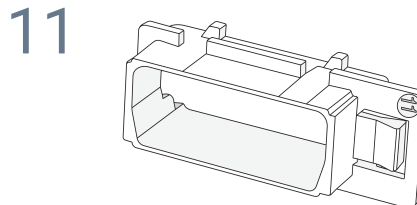

Iveco Slide & Lock

- Iveco

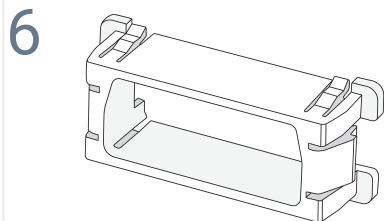

Asian Snap-In

- Toyota
- Hyundai
- Kia
- Ford
- Honda

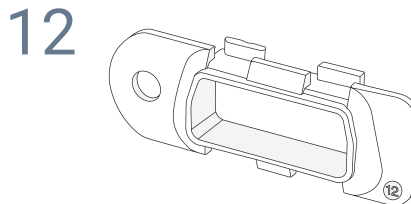

Volvo Slide Mount

- Volvo

Harness Installation Instructions

- 1 Unplug the Geotab GO device from the vehicle and remove the in-vehicle OBDII connector from its slot.

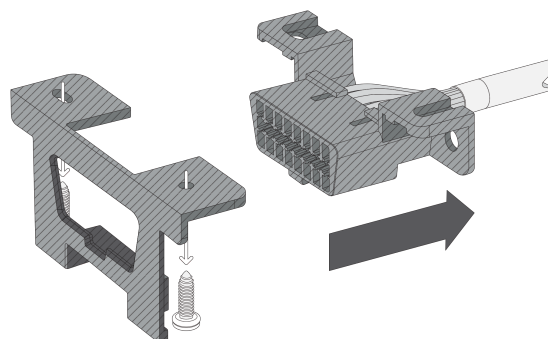

2A Attach the female universal core connector (short end) of the harness to the appropriate adapter (see Adapters section above) matching the required installation.

Note: For installation in Fiat, Citroen, or Peugeot, please refer to the European Latch & Snap installation instructions below.

Note: For installation in Ford, please refer to the Ford Round Snap-in below.

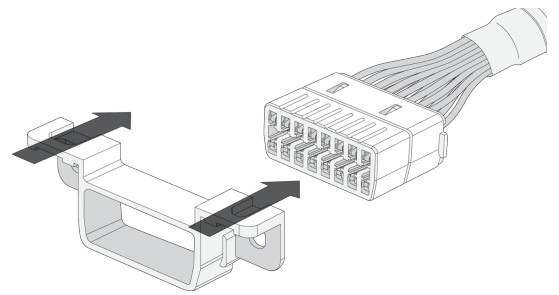

2B Secure the adapter in place using the provided metal clips. Please ensure the metal clips latch into the adapter.

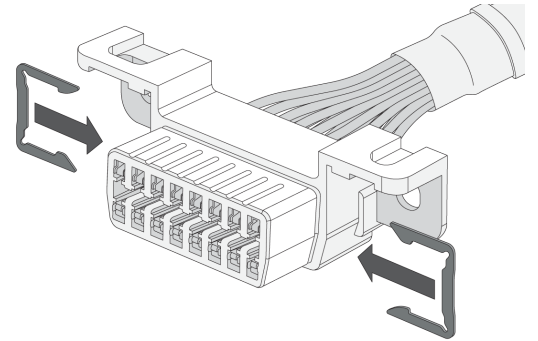

2C Fasten the female universal core connector (short end) of the harness to the vehicle's OBDII slot and secure in place using either screws or the plastic clips on the adapters.

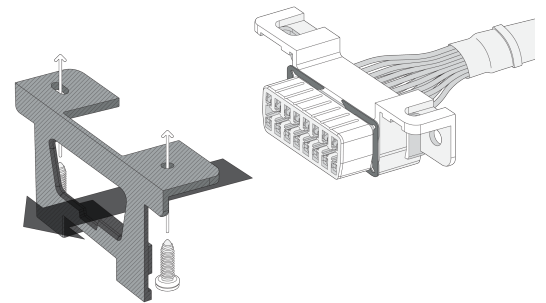

3 Connect the GO device to the female universal core connector (long end) of the harness.

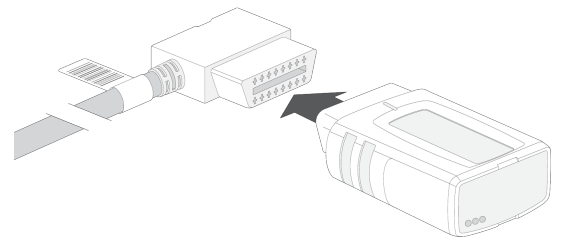

4 Connect the male OBDII harness connector to the vehicle's OBDII connector removed in Step 1.

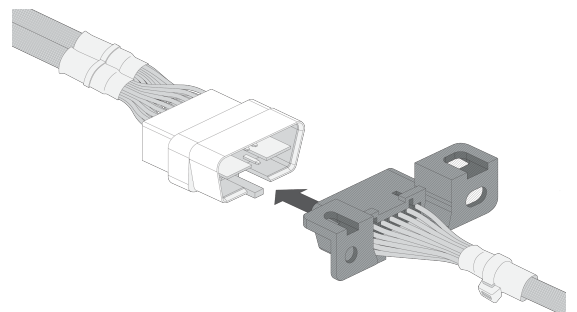

Completed Setup

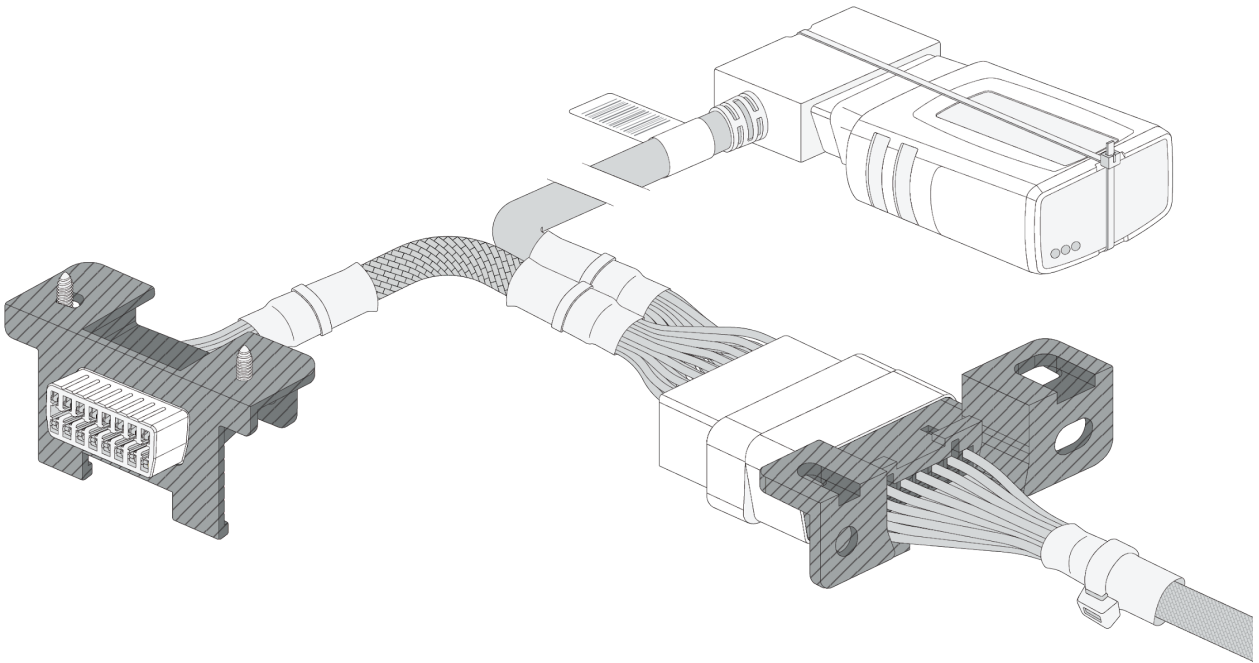

European Latch & Snap

Replace Step 2 of the standard installation instructions with the following steps for Fiat, Citroën or Peugeot vehicles using the European Latch & Snap adapter.

- 1 Slide the European Latch & Snap all the way to the back of the core connector.

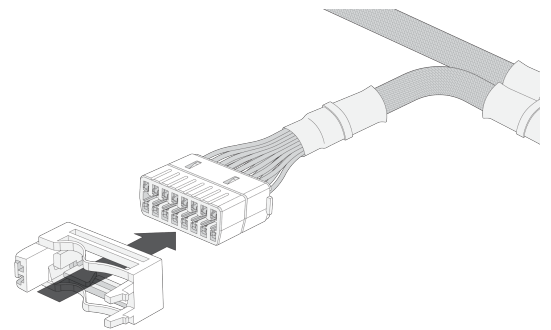

- 2 Insert the small snap adapter onto the wire behind the core connector.

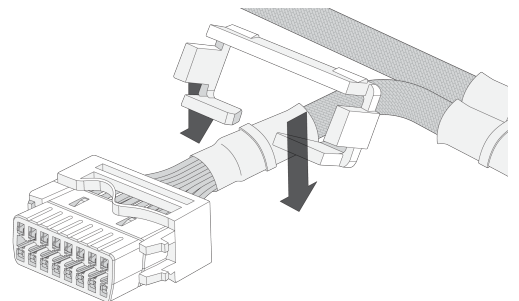

- 3 Slide the small snap adapter from the back of the harness. Ensure that the European Latch & Snap is securely interlocked.

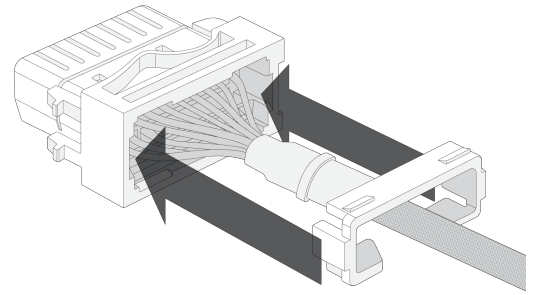

Ford Round Snap-In

Replace Step 2 of the standard installation instructions with the following steps for Ford vehicles using the Ford Round Snap-In adapter.

- 1 Slide the Ford Round Snap-In all the way to the back of the core connector.

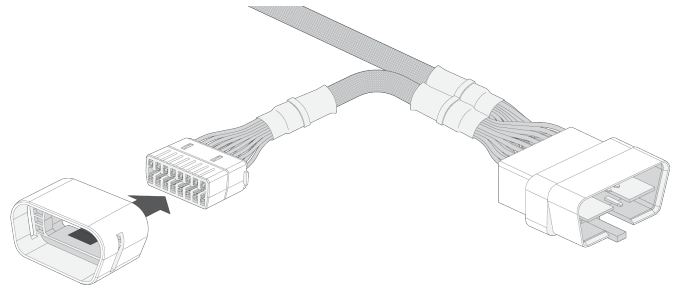

- 2 Using the insert/removal tool, secure the adapter in place using the provided metal clips. Please ensure the metal clips latch into the adapter.

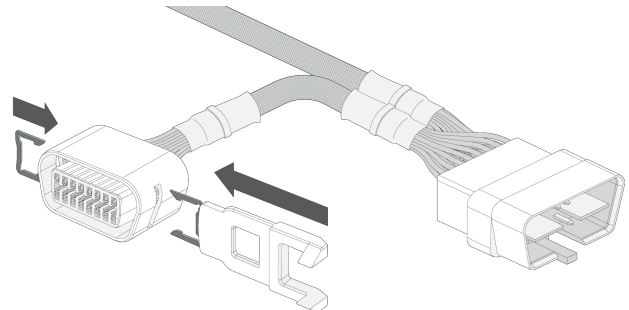

Securing the HRN-GS16K2 to the Ford OBDII Module

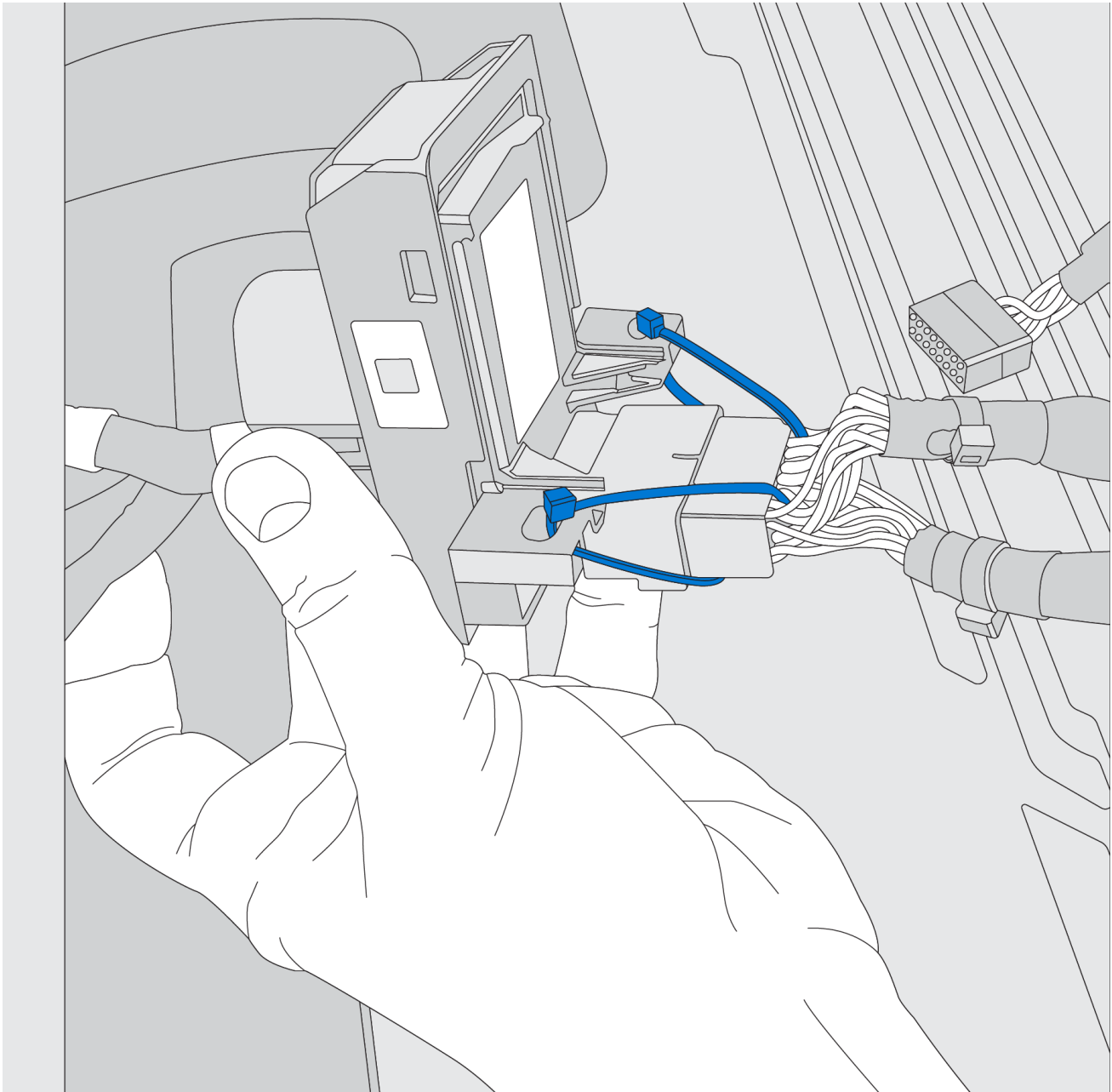

Use two zip ties to secure the HRN-GS16K2 to the factory Ford OBDII module shown above.

*** NOTE:** Over tightening the zip tie may cause damage to the harness connector.

Insertion and Removal of Metal Clips

The metal clips used to secure the adapters can be inserted by hand – except for the Ford Round Snap-In (#10) adapter. The Ford Round Snap-In adapter requires the use of the insertion end of the insert/removal tool included with the harness kit. The removal of clips requires the use of the removal end of the insert/removal tool.

Insert

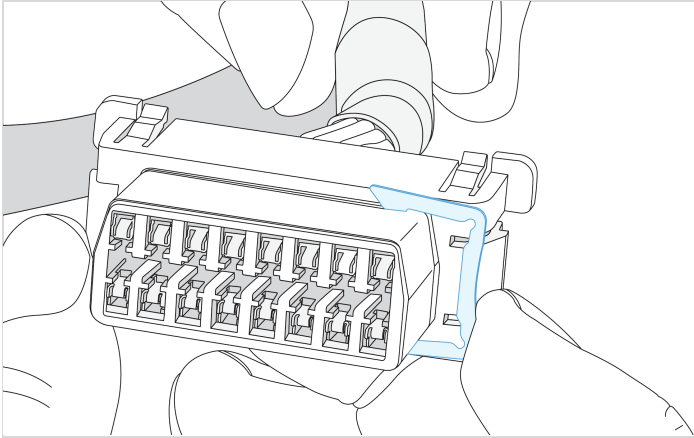

Attach the required adapter to the core connector of the harness and secure the metal clips in place with your hands.

Remove

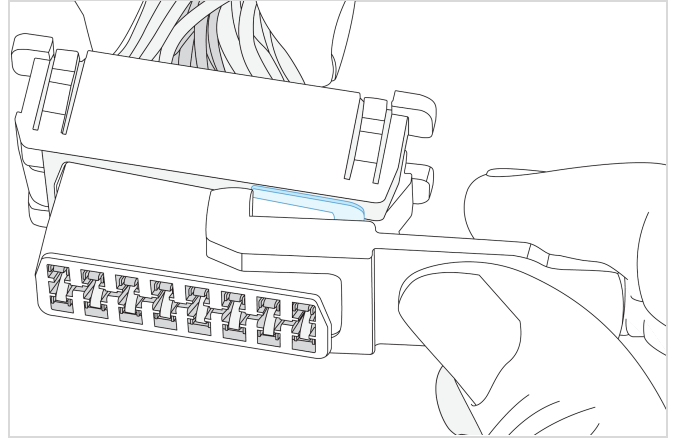

Remove the metal clips from the adapter by pulling them off using the removal end of the insertion/removal tool.

Important Safety Information and Limitations of Use

For the latest version of the Limitations of Use, please visit: goo.gl/k6Ep0w.

WARNING! Do not attempt to install, configure or remove any product from any vehicle while the vehicle is in motion or otherwise in operation. All installation, configuration or removal must be done only in stationary vehicles which are securely parked. Attempting to service units while being operated could result in malfunctions or accidents, leading to death or serious personal injury.

WARNING! All in-vehicle devices and related cabling must be securely fastened and kept clear of all vehicle controls, including gas, brake and clutch pedals. You must inspect devices and cabling on a regular basis to ensure all devices and cabling continue to be securely attached. Loose cabling or devices may impede the use of vehicle controls, resulting in unanticipated acceleration, braking or other loss of vehicle control, which could lead to death or serious personal injury. Improperly fastened in-vehicle devices may detach and impact operators upon sudden acceleration or deceleration, which may cause injury.

WARNING! If at any point after an in-vehicle device is installed a warning lights up on the vehicle dash or the vehicle stalls or has a marked drop in performance, shut off the engine, remove the device, and contact your reseller. Continuing to operate a vehicle with these symptoms can cause loss of vehicle control, and serious injury.

WARNING! Your in-vehicle devices must be kept clear of debris, water and other environmental contaminants. Failure to do so may result in units malfunctioning or short-circuiting that can lead to a fire hazard or vehicle damage or serious injury.

WARNING! Do not attempt to remove the devices from the vehicle in which they are originally installed for installation in another vehicle. Not all vehicles share compatibility, and doing so may result in unexpected interactions with your vehicle, including sudden loss of power or shutdown of the vehicle's engine while in operation or cause your vehicle to operate poorly or erratically and cause death or serious injury and/or vehicle damage.

NOTICE: This product does not contain any user-serviceable parts. Configuration, servicing, and repairs must only be made by an authorized reseller or installer. Unauthorized servicing of these products will void your product warranty.

 **WARNING:** Cancer and Reproductive Harm - www.P65Warnings.ca.gov.

CAUTION! Always use adapter harness (HRN-CG13S1) with the GO9 (pre-V2) for heavy-duty trucks to avoid possible damage to the GO9 device. For more information, see gtb.page.link/mWOF.

Regulatory Statements

Germany

Wir besitzen keine Versand- und Lagerfläche in Deutschland und sind nicht von der Rücknahmepflicht nach § 17 ElektroG betroffen.